

INGROUND LIFTS

SL135, 230/235/250, 450



SL135HP, SL135HMP, SL135RA

1-CYLINDER INGROUND LIFTS FROM BLITZROTARY ARE AVAILABLE WITH H CHASSIS AND X CHASSIS. THE H CHASSIS VERSION IS USED PRIMARILY IN THE AREA OF MAINTENANCE; THE X CHASSIS VERSION IS ESPECIALLY SUITABLE FOR BODYWORK. BOTH BOAST THE SAME RUGGED DESIGN AND THE SAME FLAWLESS QUALITY.

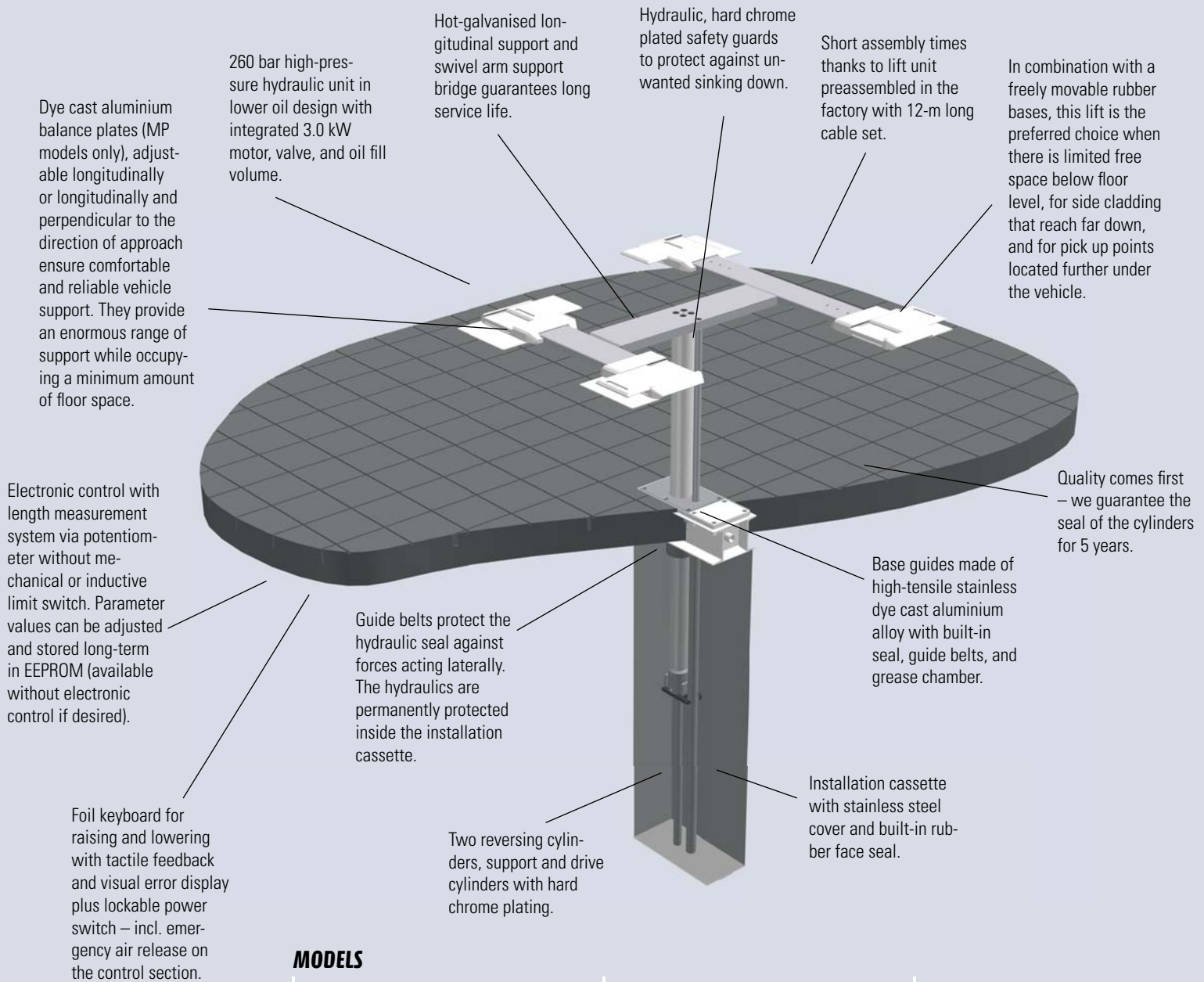

MODELS

SL135HP

1-cylinder inground lift with galvanised H chassis, with longitudinally movable drive-over platforms, mechanical foot guards, and rubber bases 70 mm.

SL135HMP

1-cylinder inground lift with galvanised H chassis, with longitudinally and transversely movable drive-over platforms, mechanical foot guards, and rubber bases 70 mm.

SL135RA

1-cylinder inground lift with galvanised X chassis and 2-part supporting arms incl. support plates.

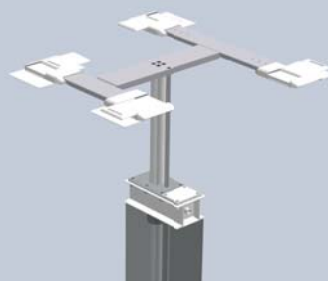
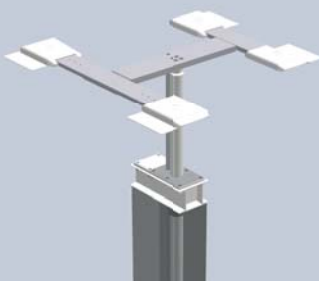

Model:	SL135HP	SL135HMP XY support	SL135RA supporting arms, 2-part
Capacity	3500 kg	3500 kg	3500 kg
Stroke	1920 mm	1920 mm	1920 mm
B. Overall length	1450-2050 mm	1450-2050 mm	-
C. Overall width	1665 mm	1665-1945 mm	-
Drive over height	60 mm	60 mm	about 95 mm
Rotary plate height min.	-	-	95 mm
Rotary plate height max.	-	-	130 mm
Support range, longitude	650-1860 mm	560-1902 mm	-
Support range, transverse	987-1587 mm	770-1900 mm	-
D. Support range	-	-	1440-2080 mm
Supporting arm length min.	-	-	615 mm
Supporting arm length max.	-	-	950 mm
Cylinder diameter	123 mm	123 mm	123 mm
Installation depth	2338 mm	2338 mm	2338 mm
Motor performance	3,0 kW	3,0 kW	3,0 kW
Electrical connection (3 phases)	230/400 V, 50 Hz	230/400 V, 50 Hz	230/400 V, 50 Hz
Lifting time	45 sec.	45 sec.	45 sec.
Lowering time	45 sec.	45 sec.	45 sec.

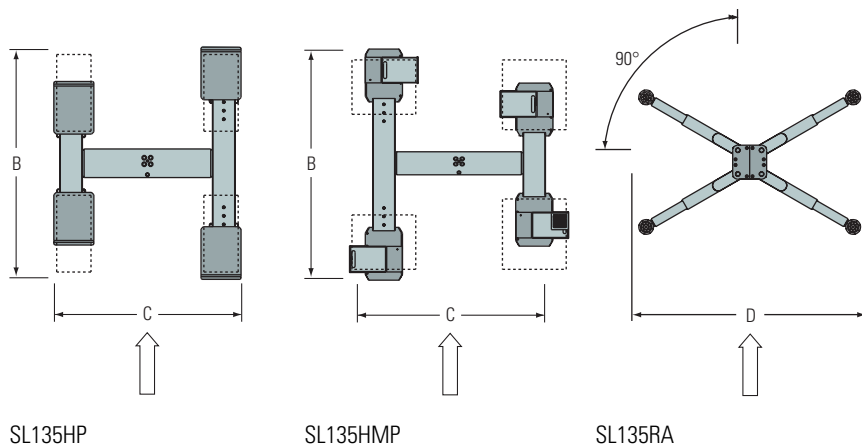

ACCESSORIES

Power distribution point (2 x 230 V / 1 x 400 V), available with or without compressed air connection.



2nd control unit



Gummi-Auflagen, 4 Stück, Höhe 20 mm / 40 mm / 70 mm (fig. similarly)

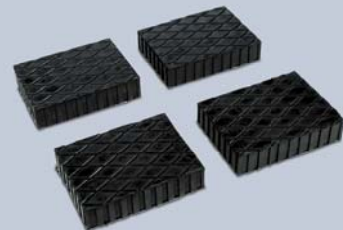

Adapter kit for sports car, 4 pieces, height 30-60 mm



Adapter kit, 4 pieces, height 102-141 / 128-198 / 198-300 mm



SL230P/SL235P, SL230MP/SL235MP

INGROUND LIFTS WITH BALANCE PLATES ARE THE PERFECT SOLUTION FOR NORMAL REPAIR WORK. ABSOLUTE FREEDOM ALL AROUND AND UNHINDERED ACCESS TO ALL AREAS OF THE VEHICLE OFFER THE BEST WORKING CONDITIONS. THE MECHANIC DOES NOT HAVE TO CONTEND WITH ABOVE-GROUND RAMS OR SWIVEL ARMS REACHING UNDER FROM OUTSIDE.

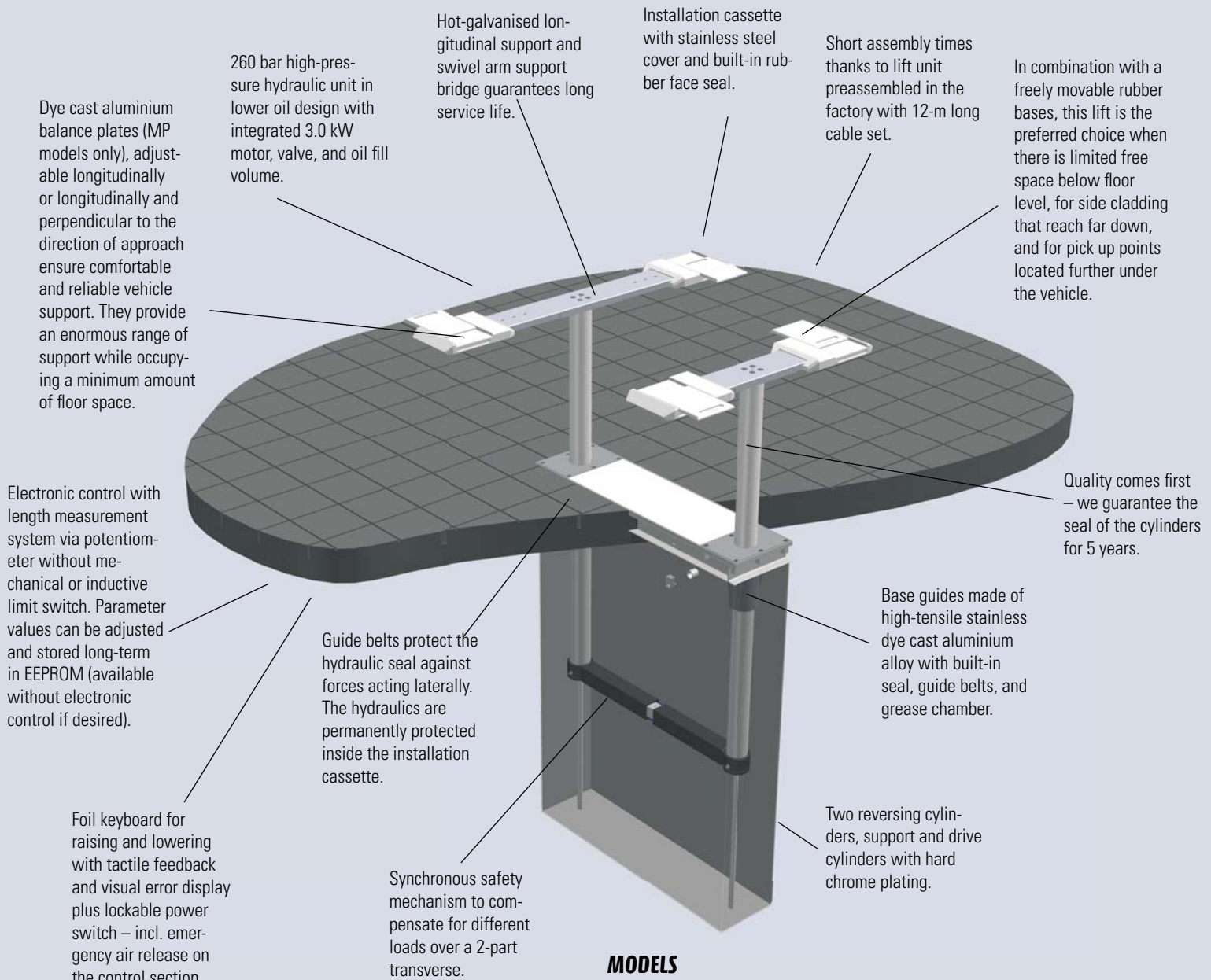

MODELS

SL230/235P

2-cylinder in-ground lift with galvanised, longitudinally movable drive-over platforms, incl. 4 rubber bases 70 mm.

SL230/235MP

2-cylinder in-ground lift with galvanised, longitudinally and transversely movable drive-over platforms, incl. 4 rubber bases 70 mm.

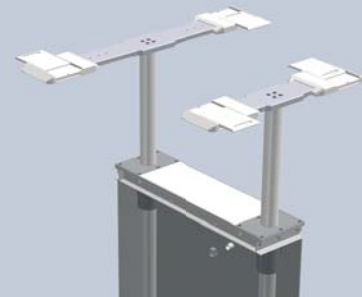
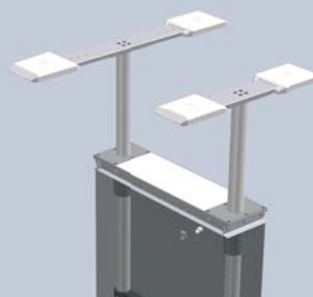

Model:	SL230P	SL235P	SL230MP XY support	SL235MP XY support
Capacity	3000 kg	3500 kg	3000 kg	3500 kg
Stroke	1920 mm	1920 mm	1920 mm	1920 mm
B. Overall length	1450-2050 mm	1450-2050 mm	1450-2050 mm	1450-2050 mm
C. Overall width	1645 mm	1645 mm	1645-1945 mm	1645-1945 mm
Drive over height	60 mm	60 mm	60 mm	60 mm
Support range, longitude	650-1860 mm	650-1860 mm	650-1902 mm	650-1902 mm
Support range, transverse	1085-1585 mm	1085-1585 mm	770-1900 mm	770-1900 mm
Cylinder diameter	123 mm	123 mm	123 mm	123 mm
F. Cylinder spacing	1335 mm	1335 mm	1335 mm	1335 mm
Installation depth	2338 mm	2338 mm	2338 mm	2338 mm
Motor performance	3,0 kW	3,0 kW	3,0 kW	3,0 kW
Electrical connection (3 phases)	230/400 V, 50 Hz	230/400 V, 50 Hz	230/400 V, 50 Hz	230/400 V, 50 Hz
Lifting time	40 sec.	40 sec.	40 sec.	40 sec.
Lowering time	40 sec.	40 sec.	40 sec.	40 sec.

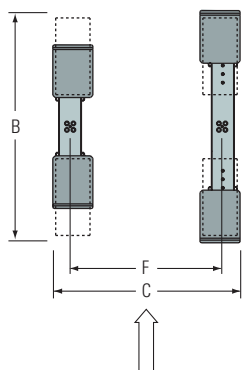

SL230/235P

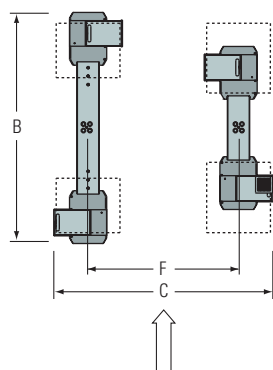

SL230/235MP

Rubber bases, 4 pieces, height 20 mm
(fig. similarly)

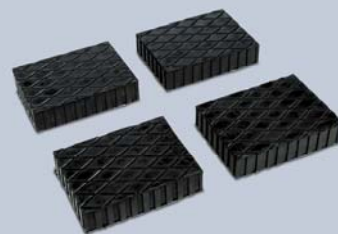

ACCESSORIES

Power distribution point (2 x 230 V /
1 x 400 V), available with or without
compressed air connection.



Rubber bases, 4 pieces, height 40 mm
(fig. similarly)

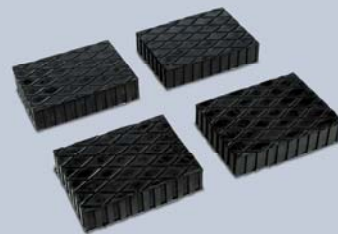

2nd control unit



Rubber bases, 4 pieces, height 70 mm
(fig. similarly)



SL235DOP/SL235DOR-DP

INGROUND LIFTS WITH DRIVE SURFACES ARE ESPECIALLY SUITABLE FOR DIRECT RECEIVING AND THE REPAIR AREA – AND, WITH OPTIONAL WHEEL ALIGNMENT KIT, ALSO FOR WHEEL ALIGNMENT. THE SL235DOP CAN BE RETROFITTED WITH A JACKING BEAM. THE SL235DOR-DP COMES STANDARD EQUIPPED WITH A JACKING BEAM BUILT INTO THE DRIVE SURFACE.

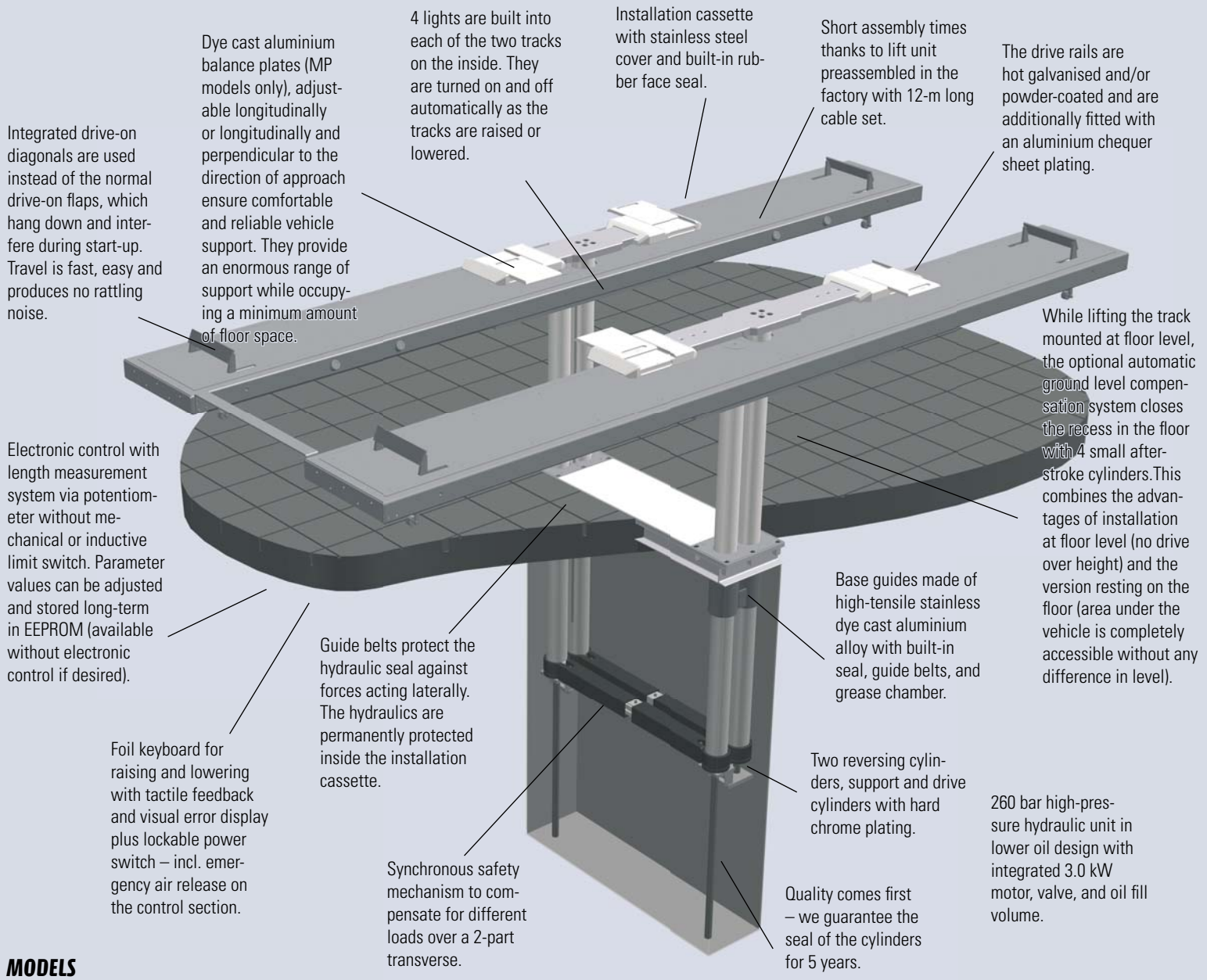

Integrated drive-on diagonals are used instead of the normal drive-on flaps, which hang down and interfere during start-up. Travel is fast, easy and produces no rattling noise.

Dye cast aluminium balance plates (MP models only), adjustable longitudinally or longitudinally and perpendicular to the direction of approach ensure comfortable and reliable vehicle support. They provide an enormous range of support while occupying a minimum amount of floor space.

4 lights are built into each of the two tracks on the inside. They are turned on and off automatically as the tracks are raised or lowered.

Installation cassette with stainless steel cover and built-in rubber face seal.

Short assembly times thanks to lift unit preassembled in the factory with 12-m long cable set.

The drive rails are hot galvanised and/or powder-coated and are additionally fitted with an aluminium chequer sheet plating.

Electronic control with length measurement system via potentiometer without mechanical or inductive limit switch. Parameter values can be adjusted and stored long-term in EEPROM (available without electronic control if desired).

While lifting the track mounted at floor level, the optional automatic ground level compensation system closes the recess in the floor with 4 small after-stroke cylinders. This combines the advantages of installation at floor level (no drive over height) and the version resting on the floor (area under the vehicle is completely accessible without any difference in level).

Foil keyboard for raising and lowering with tactile feedback and visual error display plus lockable power switch – incl. emergency air release on the control section.

Guide belts protect the hydraulic seal against forces acting laterally. The hydraulics are permanently protected inside the installation cassette.

Base guides made of high-tensile stainless dye cast aluminium alloy with built-in seal, guide belts, and grease chamber.

Two reversing cylinders, support and drive cylinders with hard chrome plating.

Synchronous safety mechanism to compensate for different loads over a 2-part transverse.

Quality comes first – we guarantee the seal of the cylinders for 5 years.

260 bar high-pressure hydraulic unit in lower oil design with integrated 3.0 kW motor, valve, and oil fill volume.

MODELS

SL235DOP

2-cylinder inground lift with galvanised and aluminium-plated (aluminium chequer sheet) tracks, with 4 halogen lights integrated inside the platforms, on and off switch functionality for raising and lowering, including 4 rubber bases 70 mm, 4 x drive-on limiting, 1 x cross brace for optionally connecting platforms together and 4 x drive-on wedges length 400 mm

SL235DOR-DP

2-cylinder inground lift with galvanised and aluminium-plated (aluminium chequer sheet) tracks, and additional support platforms (MP), with longitudinally and transversally movable aluminium supports and 4 halogen lights integrated inside the platforms, on and off switch functionality for raising and lowering, including 4 rubber bases 70 mm, 4 x drive-on limiting, 1 x cross brace for optionally connecting platforms together and 4 x drive-on wedges length 400 mm

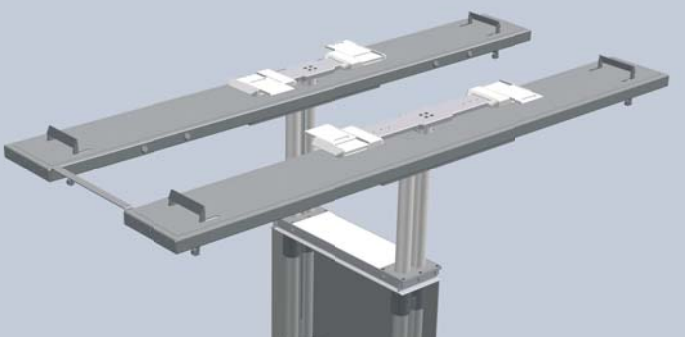

Model:	SL235DOP	SL235DOR-DP XY support
Capacity	3500 kg	3500 kg
Stroke	1980 mm	1980 mm
Lifting table stroke	-	160 mm
Overall length with drive-on ramps	5820 mm	5820 mm
C. Overall width	2100 mm	2100 mm
Closed height	120 mm	120 mm
D. Platform length	5010 mm	5010 mm
E. Platform length of lifting table	-	1450-2050 mm
F. Platform width	600 mm	600 mm
G. Platform width of lifting table	-	330-610 mm
Wheelbase	2100-3800 mm	2100-3800 mm
Support range, wheel free, longitudinal	-	650-1860 mm
Support range, wheel free, transverse	-	770-1900 mm
Cylinder diameter	123 mm	123 mm
H. Cylinder spacing	1335 mm	1335 mm
Installation depth	2338 mm	2443 mm
Motor performance	3,0 kW	3,0 kW
Electrical connection (3 phases)	230/400 V, 50 Hz	230/400 V, 50 Hz
Lifting time	40 sec.	40 sec.
Lowering time	40 sec.	40 sec.

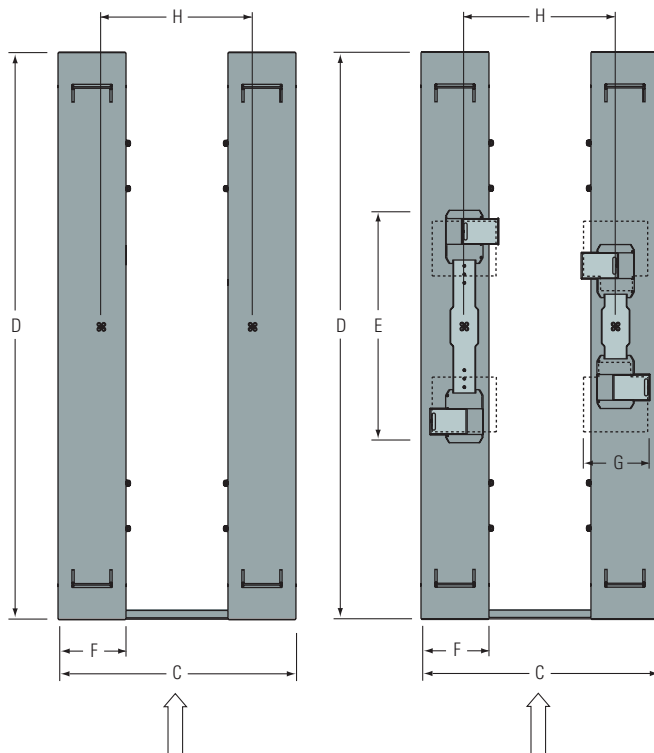

SL235DOP

SL235DOR-DP

ACCESSORIES

Power distribution point (2 x 230 V / 1 x 400 V), available with or without compressed air connection.



Rubber bases, 4 pieces, height 20 mm / 40 mm / 70 mm (fig. similarly)

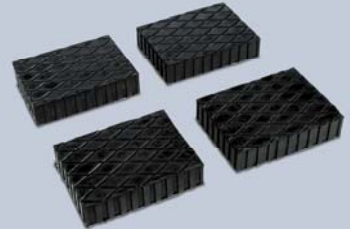

2nd control unit



Additional wheel alignment supports (600 mm)



Jacking beam, capacity 2,000 kg (SL235DOP only)



Wheel alignment supports (1,350 mm)



Installation frame as a lost form-work, for installation at floor level



Additional wheel alignment supports (600 mm)



Automatic floor level compensation (only in combination with installation frame). Recesses in the floor are automatically closed when the tracks are lifted, thus ensuring safe work under the vehicle without trip hazards.



Hydraulic articulation clearance testing device



SL235S2/S3, SL235RA/SL250RA/, SL235BR, SL250BR-RA

DUE TO THEIR NUMEROUS ADJUSTMENT OPTIONS, INGROUND LIFTS WITH SWIVEL ARMS ARE SUITABLE FOR NEARLY ALL REPAIR JOBS. COMPARED TO THE S2/S3 ENTRY-LEVEL MODELS, THE SWIVEL ARMS FOR THE RA MODELS ARE FASTENED ONTO A SLIDER, AND CAN THEREFORE BE MORE FINELY ADJUSTED. THE SPECIAL STRENGTHS OF THE BR MODELS ARE ESPECIALLY SUITABLE FOR BODYWORK.

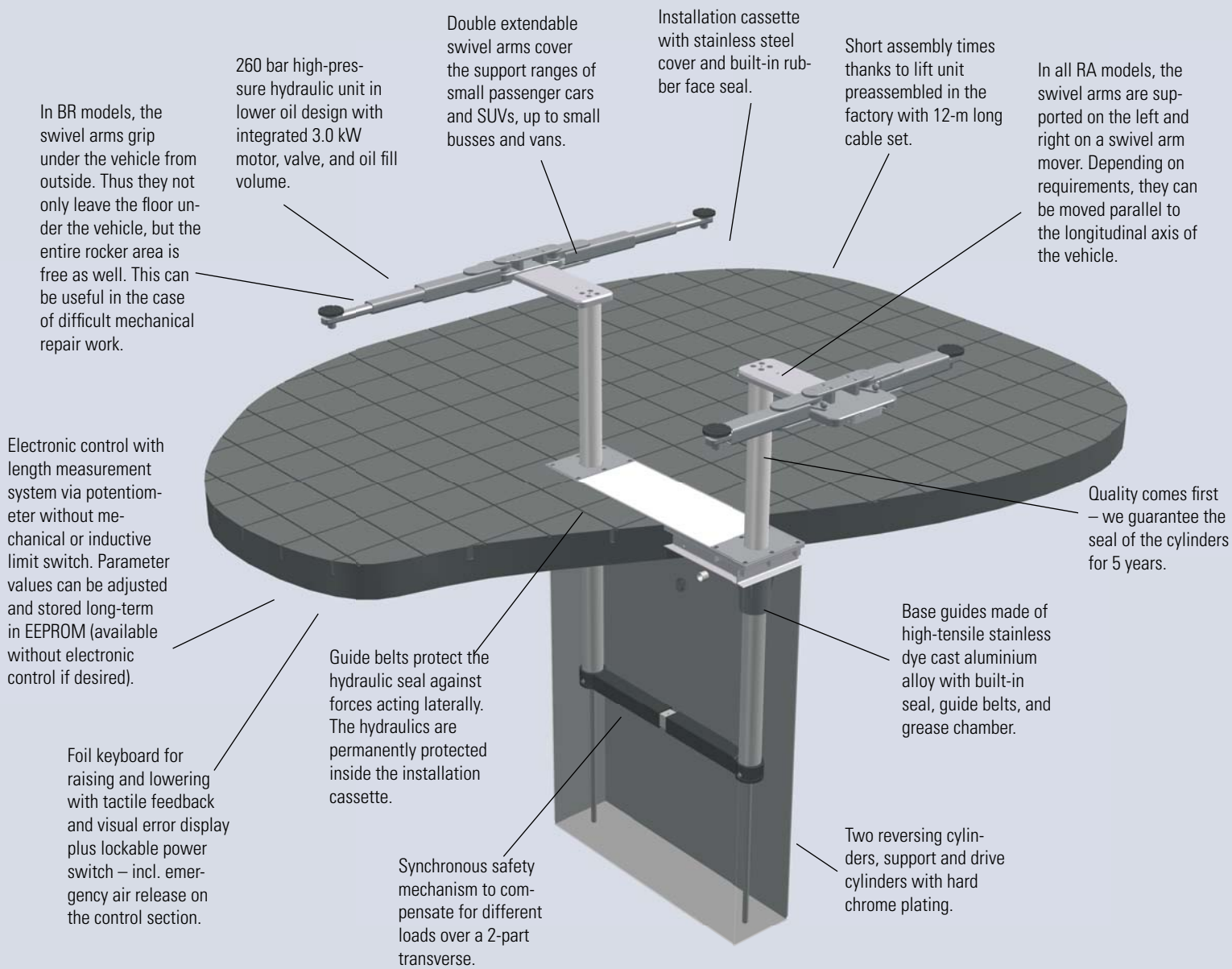

MODELS

SL235S2/S3

2-cylinder in-ground lift with bolted-on galvanised 2-part (S2) or 3-part supporting arms, including support plates.

SL235/250RA

2-cylinder in-ground lift with galvanised 3-part supporting arms. Supporting arm holders can be moved perpendicularly to the driving direction, thus making it possible to support most popular vehicle models; incl. support plates.

SL235BR

2-cylinder in-ground lift with 2-part supporting arms, specially designed for bodywork, incl. support plates.

SL250BR-RA

2-cylinder in-ground lift with galvanised 3-part supporting arms, including support plates.

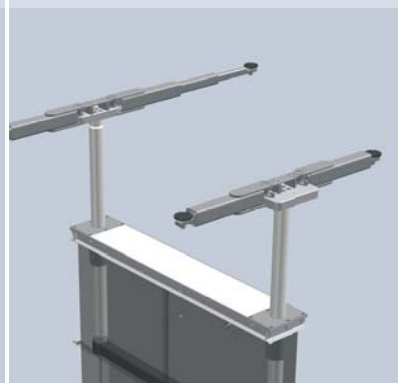

Models:	SL235S2 supporting arms, 2-part	SL235S3 supporting arms, 3-part	SL235RA supporting arms, 3-part transversely movable	SL250RA supporting arms, 3-part transversely movable	SL235BR supporting arms, 2-part longitudinally movable	SL250BR-RA supporting arms, 3-part
Capacity	3500 kg	3500 kg	3500 kg	5000 kg	3500 kg	5000 kg
Stroke	1960 mm	1960 mm	1960 mm	1890 mm	1960 mm	1880 mm
B. Overall length	1780-2562 mm	1520-2760 mm	1540-2540 mm	1960-3600 mm	2000 mm	1960-3600 mm
C. Overall width	2157 mm	2157 mm	2800 mm	3200 mm	2676 mm	2655 mm
Rotary plate height min.	100 mm	107 mm	102 mm	114 mm	103,5 mm	114 mm
Rotary plate height max.	135 mm	143 mm	141 mm	153 mm	194,5 mm	153 mm
D. Supporting arm length min.	750 mm	620 mm	600 mm	800 mm	519 mm	800 mm
E. Supporting arm length max.	1141 mm	1240 mm	1100 mm	1620 mm	809 mm	1620 mm
Cylinder diameter	123 mm	123 mm	123 mm	123 mm	123 mm	123 mm
F. Cylinder spacing	1335 mm	1335 mm	1335 mm	1335 mm	2285 mm	2285 mm
Installation depth	2338 mm	2338 mm	2338 mm	2338 mm	2338 mm	2338 mm
Motor performance	3,0 kW	3,0 kW	3,0 kW	3,0 kW	3,0 kW	3,0 kW
Electrical connection (3 phases)	230/400 V, 50 Hz	230/400 V, 50 Hz	230/400 V, 50 Hz	230/400 V, 50 Hz	230/400 V, 50 Hz	230/400 V, 50 Hz
Lifting time	40 sec.	40 sec.	40 sec.	50 sec.	40 sec.	50 sec.
Lowering time	40 sec.	40 sec.	40 sec.	50 sec.	40 sec.	50 sec.

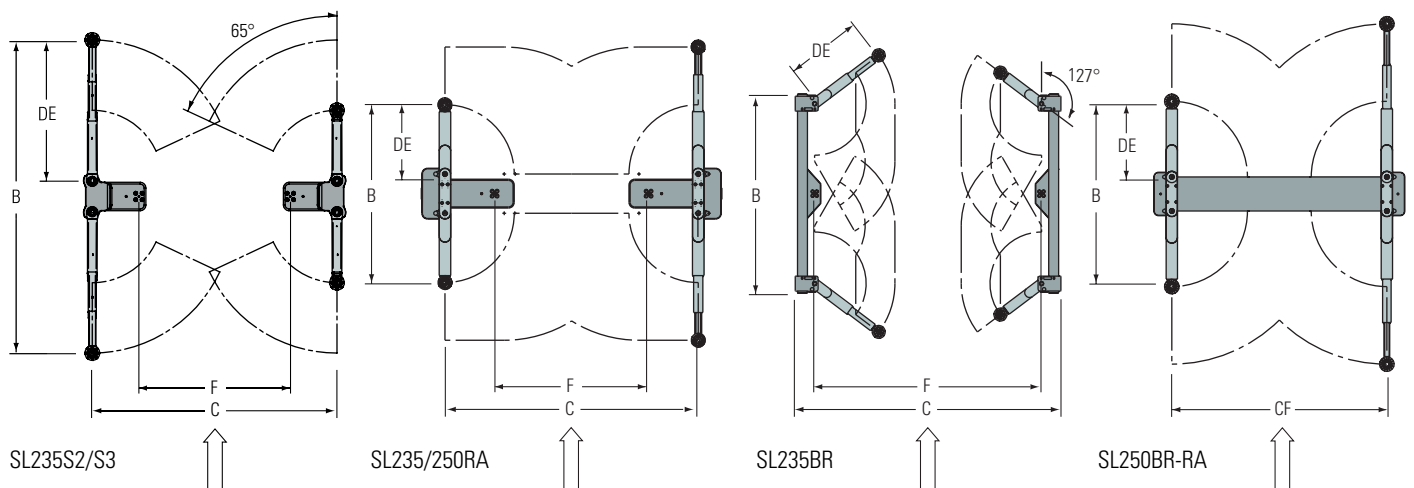

Adapter kit for sports car, 4 pieces, height 30-60 mm

ACCESSORIES

Power distribution point (2 x 230 V / 1 x 400 V), available with or without compressed air connection.



2nd control unit



Adapter kit, 4 pieces, height 102-141 / 128-198 / 198-300 mm



SL450DOP

THE SL450DOP IS A NEW VERSION FURTHER EXTENDING THE WIDE RANGE OF USES FOR THE INGROUND LIFTING SYSTEM. 4 LIFTING UNITS USED TOGETHER WITH LOCK RODS MAKE IT POSSIBLE TO USE AS A WHEEL ALIGNMENT LIFT. OF COURSE THERE IS ALSO NO REASON NOT TO USE THE LIFT FOR DIRECT RECEIVING OR REPAIRS AS WELL.

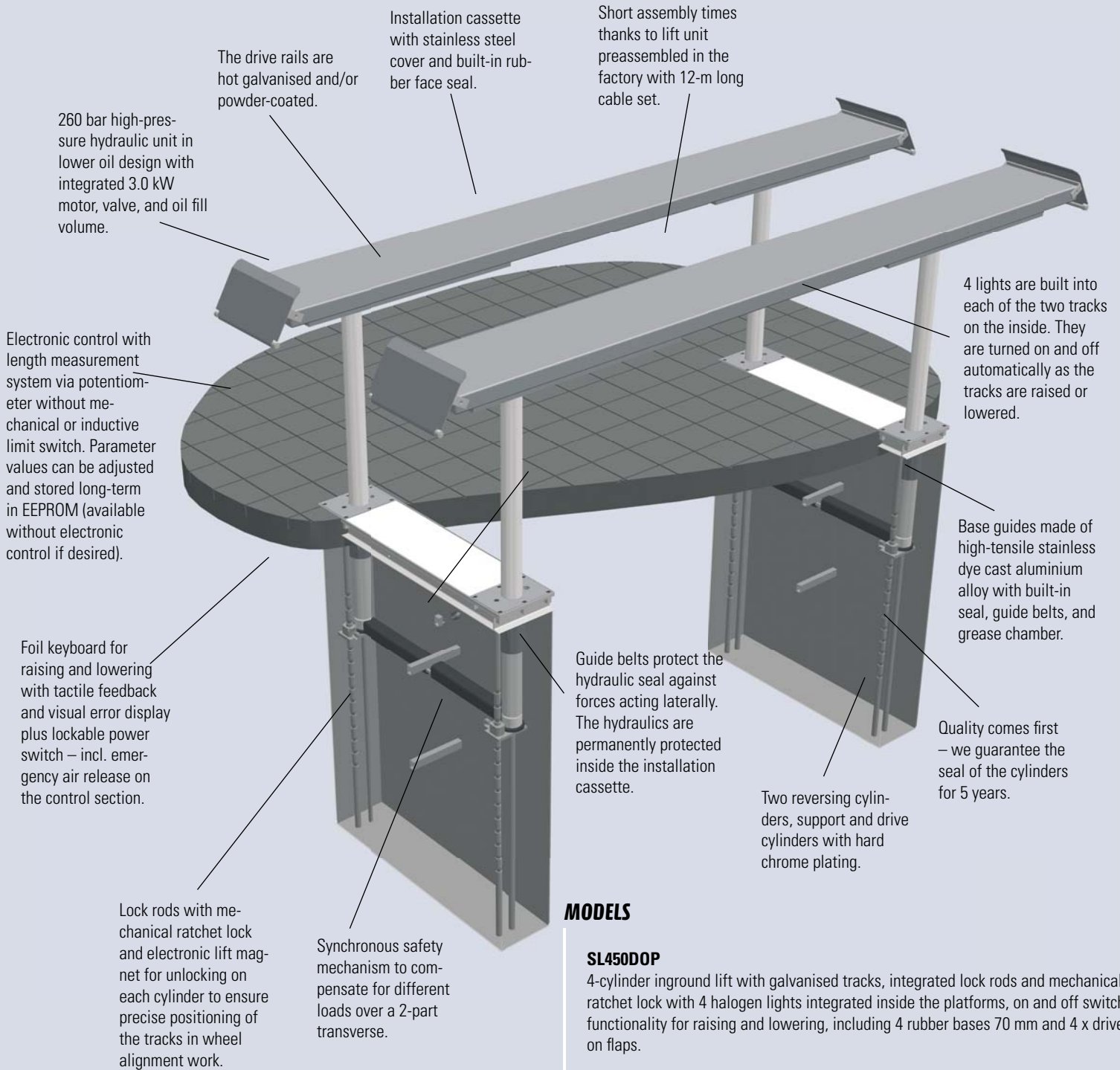

MODELS

SL450DOP

4-cylinder inground lift with galvanised tracks, integrated lock rods and mechanical ratchet lock with 4 halogen lights integrated inside the platforms, on and off switch functionality for raising and lowering, including 4 rubber bases 70 mm and 4 x drive-on flaps.

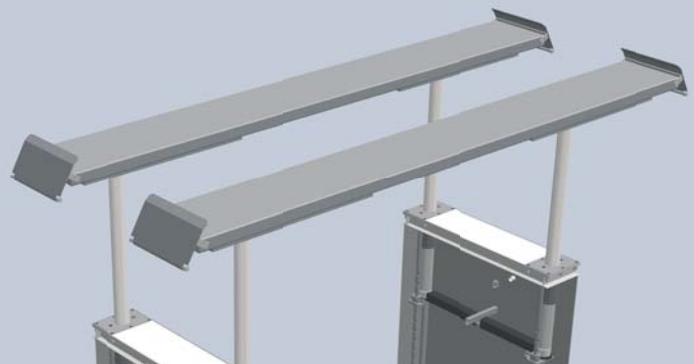

Model:	SL450DOP
Capacity	4500 kg
Stroke	1990 mm
Overall length with drive-on ramps (short/long)	5585/6860 mm
C. Overall width	2100 mm
Closed height	130 mm
D. Platform length	5200 mm
F. Platform width	600 mm
Wheelbase	max. 4600 mm
Cylinder diameter	123 mm
H. Cylinder spacing, transverse direction	1335 mm
I. Cylinder spacing longitudinal direction	3500 mm
Installation depth	2443 mm
Motor performance	2 x 3,0 kW
Electrical connection (3 phases)	230/400 V, 50 Hz
Lifting time	45 sec.
Lowering time	45 sec.

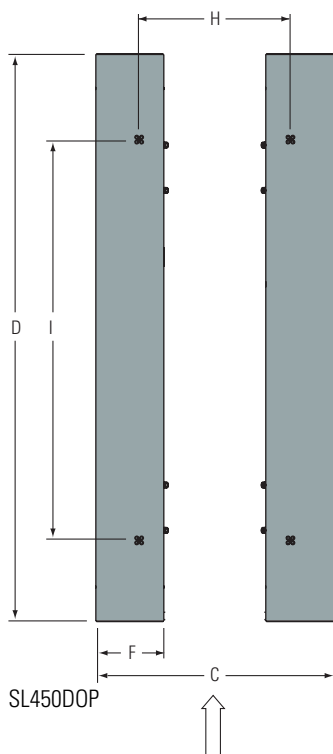

OPTIONS

Drive-on flaps short (for installation at floor level)

Drive-on flaps long (for installation resting on the floor)

ACCESSORIES

Power distribution point (2 x 230 V / 1 x 400 V), available with or without compressed air connection.



Aluminium plating of tracks



2nd control unit



Cross brace for additional stabilisation of tracks



Hydraulic articulation clearance testing device



Jacking beam, capacity 2,000 kg



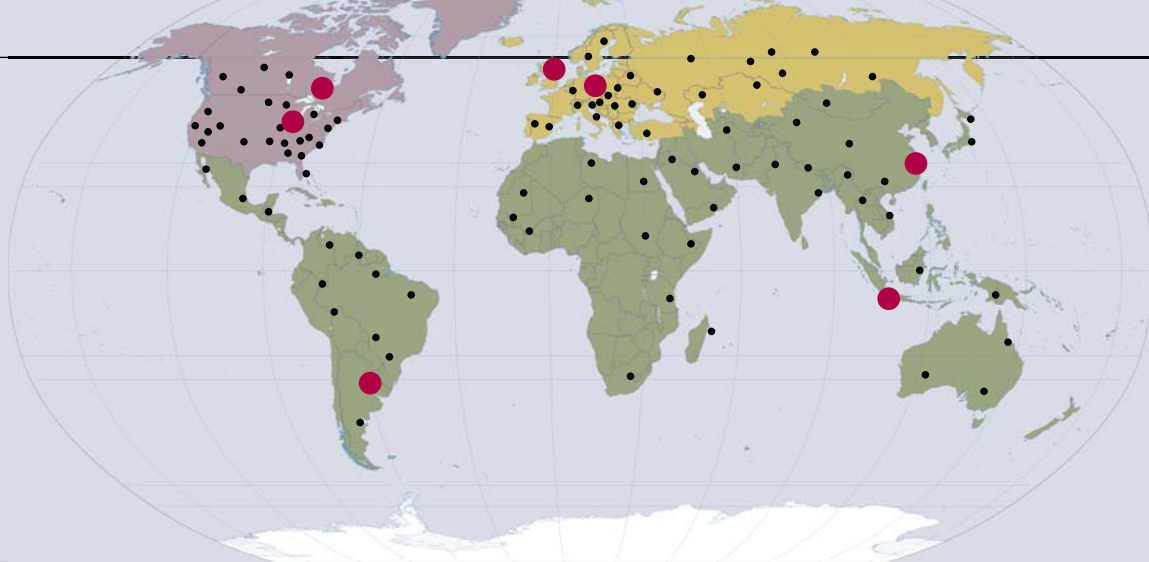

LOOK LOCAL - ACT GLOBAL

WE ACT WITH FOCUS ON OUR CUSTOMERS AND THEIR REQUIREMENTS. LOCAL SUBSIDIARIES WORLDWIDE PERMIT US TO DO SO, AND AT THE SAME TIME, OFFER A HIGH DEGREE OF PRODUCT FLEXIBILITY.

Rotary Lift's story of success started in 1924. Inspired by a barber chair rising in the air, company founder Peter Lunati developed the world's first vehicle lift. The lift could rotate. This design made it possible for vehicles to drive on and off the lift in forward gear. An important argument considering the frequent problem of reversing at that time. The patent for the lift was granted on September 1, 1925 and Rotary Lift – the company – was born.

Over 75 years later, Rotary Lift has grown to become the world leader in vehicle lift productivity. Apart from the headquarters in Madison, Indiana (USA) and the European Control Center in Bräunlingen, Germany, numerous global subsidiaries attend to the desires and requirements of our customers.

With this unique network, Rotary Lift has the opportunity of analyzing and recognizing market trends at an early stage and of applying that knowledge to generate global standards. Worldwide product releases of numerous vehicle manufacturers emphasize this approach.



Headquarter
Madison, IN USA

European Control Center
Bräunlingen, Germany

Rotatable
One of the first lifts of Rotary Lift



BlitzRotary GmbH
Hüfanger Straße 55
D-78199 Bräunlingen
A **DOVER** COMPANY

Telefon +49.771.9233.0
Telefax +49.771.9233.99
europe@rotarylif.com
www.rotarylif.com

USA: +1.812.273.1622 (Headquarter)
Canada: +1.905.812.9920
United Kingdom: +44.178.747.7711
AustralAsia: +60.3.7660.0285

